



Removal of MS-2 and PRD-1 bacteriophages from an ultrapure water system

RA Governal¹ and CP Gerba²

¹International Innovative Technologies, 5761 West Creda Street, Tucson, AZ 85735; ²Department of Microbiology and Immunology, University of Arizona, Tucson, AZ 85721, USA

Viruses must be removed from the ultrapure water environment, as they have the potential to deposit on microelectronic devices and generate killer defects. Controlled and well-defined challenges by MS-2 and PRD-1 bacteriophages were treated in a pilot-scale ultrapure water system using ultraviolet radiation (UV), ozone, mixed bed ion exchange adsorption, and reverse osmosis filtration technologies typical of those used in industrial systems. Applying a first order kinetic model to the data generated rate constants for MS-2 removal by UV-185, 50 mg L⁻¹ ozone, mixed bed ion exchange or reverse osmosis filtration of 15.5, 12.9, 3.9, and 10.4 min⁻¹, respectively, and PRD-1 removal of 13.8, 15.5, 8.2, and 11.9 min⁻¹, respectively. In all cases, removal of viruses by oxidative mechanisms such as ozone and UV were far superior to adsorption and filtration mechanisms. A theoretical viral population balance was generated to model the removal of the bacteriophages by these unit operations. This model relates the inlet time-dependent profile of viruses to the output, destruction, and accumulation profiles; it also relates these profiles to the unit operation's treatment mechanisms including oxidation, adsorption, and filtration. This model is the first step in generating a site-independent theoretical model to project the persistence of viruses in ultrapure water systems.

Keywords: viruses; coliphage; inactivation; reverse osmosis; ion exchange; ultraviolet light (UV); ozone

Introduction

As computer chip technology advances, the contaminant requirements for water continue to decrease from the parts per million (mg L⁻¹) concentration, through the parts per billion (ng L⁻¹), and beyond. Although previous work has shown examples of the contaminant requirements for bacteria, for particles in the 50-nm range, and for organics and dissolved elemental contaminants [1,2], current ultrapure water treatment systems have yet to specify concentration limits for viruses. Since the current microchip technology has the potential to fail when virus-sized particles are inadvertently deposited during the manufacturing process [8], the continued trend to make the circuits smaller and more complicated [8] may drive contamination limits beyond current measurement technologies. Contamination specifications may one day specify viruses as well as viral breakdown products within these systems.

Previous work has shown the effect of ultrapure water environments on virus inactivation [5] as well as the action of accepted unit operations on removal of non-viral contaminants including total oxidizable carbon (TOC), bacteria, dissolved ionic contaminants, and dissolved gases [1]. A formal study to determine the effect of these unit operations on removing indicator bacteriophages such as MS-2 and PRD-1 have not been performed in an ultrapure water environment.

This study was designed to address present and future requirements of the microelectronics industry for the

characterization and removal of bacteriophages in and from an ultrapure water system.

In addition to the physical comparisons of the data generated through direct graphing and simple first order kinetic modelling, a second and more comprehensive theoretical model is being developed to describe the effect of individual unit operations in removing bacteriophages. Although such a model has been put forward to describe the removal of organic contaminants and particles from ultrapure water treatment systems [4], no such model exists for removal of viral challenges.

By linking equations for the individual unit operations, a theoretical model can be developed to describe bacteriophage removal from ultrapure water systems. A complete theoretical model based on this and additional experimentation is the subject of future work.

Materials and methods

Water

Source water from the Martin Street well, located at the University of Arizona, Tucson, AZ, was transported to a pilot Ultrapure Water Pilot System as described by Governal *et al* [5] and to a portable reverse osmosis system (Protec, Carpinteria, CA, USA). Chemical and physical properties of water samples (Table 1) were determined according to *Standard Methods for Water and Wastewater Analysis* [4]. One-liter high density polyethylene containers were used to collect water samples. The containers were rinsed with ultrapure water [7], and sterilized by autoclaving them prior to use. Water was stored at 21°C for the duration of the experiment.

Table 1 Physical and chemical properties of city water used in this study

Property	Value
pH	7.6
Temperature (°C)	21
Hardness (mg L ⁻¹ CaCO ₃)	130
Total dissolved solids (mg L ⁻¹)	280
Turbidity (NTU)	<1
Calcium (mg L ⁻¹)	37
Magnesium (mg L ⁻¹)	4.7
Sodium (mg L ⁻¹)	38
Potassium (mg L ⁻¹)	2.0
Manganese (mg L ⁻¹)	<0.05
Chloride (mg L ⁻¹)	16
Sulfate (mg L ⁻¹)	48
Fluoride (mg L ⁻¹)	0.4
Nitrate (mg L ⁻¹)	2.0
Trihalomethanes (mg L ⁻¹)	<0.005
Conductivity (micromhos)	390
Lead (mg L ⁻¹)	<0.005
Iron (mg L ⁻¹)	<0.1
Copper (mg L ⁻¹)	<0.1
Zinc (mg L ⁻¹)	<0.03
MS-2 Bacteriophages (pfu ml ⁻¹)	<1
PRD-1 Bacteriophages (pfu ml ⁻¹)	<1

Preparation and assay of purified coliphages MS-2 and PRD-1

Cultures of *Escherichia coli* (ATCC 15597) and *Salmonella typhimurium* (ATCC 19585), grown for 18 h in tryptic soy broth (TSB; Difco, Detroit, MI, USA) at 37°C with no shaking, were used to inoculate fresh TSB. These inocula were incubated for 3–6 h at 37°C with continuous shaking to obtain fresh cultures. Stock MS-2 (ATCC 15597B) and PRD-1 were serially diluted in Tris-buffered saline, pH 7.3 (Trizma base; Sigma, St Louis, MO, USA) to approximate concentrations of 10⁵ pfu ml⁻¹. One-tenth ml MS-2 phage dilution and 1 ml *E. coli* culture as well as 0.1 ml PRD-1 phage dilution and 1 ml *S. typhimurium* culture were added to tubes of molten overlay agar (TSB with 1% agar) and mixed. The mixtures were poured into petri dishes containing tryptic soy agar (TSA; Difco). After 18–24 h of incubation at 37°C, 6–7 ml Tris was added to plates with confluent plaques; the plates were allowed to sit for a maximum of 1 h to allow the phage to diffuse through the agar surface. The liquid fraction was recovered from the plates and centrifuged (15 300 × *g* for 10 min at 10°C), and the resulting supernatant was centrifuged again (100 000 × *g* for 3 h at 10°C). The pellet was resuspended in sterile Tris buffer and stored at 4°C. Phage stocks were titered prior to use.

Serial dilutions were made in Tris buffer, added to test tubes containing 3 ml of molten overlay agar and 1 ml of 3- to 6-h cultures of *E. coli* or *S. typhimurium*. The mixture was poured onto TSA plates. The plates were incubated for 18–24 h at 37°C, after which the plaques were enumerated and the log reduction and inactivation rates of MS-2 and PRD-1 calculated.

Experimental design

Water for this study was collected from two sources. (1) Samples from the ultrapure water pilot system included

[5]: upstream and downstream from the ultraviolet sterilizer (Aquafine, Valencia, CA, USA) as shown in Figure 1a, upstream and downstream from the 50 ppb ozone injection system (Ozone Research and Equipment Corporation, Phoenix, AZ, USA) as shown in Figure 1b, upstream and downstream from the mixed bed ion exchange system (Nuclear Grade Mixed Resin, Ionpure, Bedford, MA, USA) as shown in Figure 1c. (2) Samples from the portable reverse osmosis system included: inlet (Feed), downstream of the RO membrane (Permeate), and the waste stream (Concentrate) as shown in Figure 1d (Protec, Carpinteria, CA, USA).

Experiments were performed in duplicate at room temperature (23 ± 2°C). Purified stock viruses were added to the respective sample points at time zero. At predetermined time intervals, 1.0-ml samples from the sample points indicated were assayed for bacteriophage.

Data analyses

Linear regression analyses were used to calculate inactivation rates for each experimental system. The inactivation rate (*k*) can be expressed by the equation:

$$k = -(\log_{10}(N_t/N_o))/\tau$$

where *N_t* and *N_o* are the final and initial viral concentrations in plaque-forming units per liter (pfu ml⁻¹), respectively, and τ represents residence time in the unit operation in minutes. All residence times have been fixed at 24.4 s or 0.4067 min, respectively. Student's *t*-test [9] was used for analysis of variance to determine significant differences in inactivation rates among various water environments; confidence limits were set at 90% unless stated otherwise.

General viral population balance

A general viral population balance, adapted from a general population balance [12] may be performed on each of the unit operations as displayed in Figure 1 to determine their abilities to remove viruses from a water treatment system:

$$\text{Input} + \text{Generation} = \Sigma \text{Output} + \text{Destruction} + \text{Accumulation} \quad (1)$$

The input rate is defined as the number of viruses injected into the system in plaque-forming units per minute (pfu min⁻¹). The generation rate is defined as the number of viruses released from infected bacteria within the component (pfu min⁻¹) and is assumed to be negligible for this experiment. The output rate is defined as the number of viruses leaving the system in plaque-forming units per minute (pfu min⁻¹). Note that for the reverse osmosis unit, the rates are divided into concentrate flow and permeate flow; all other unit operations shown have only one output rate.

Using the term 'Pin' to denote the rate of viruses entering the unit operation (pfu ml⁻¹), and assigning similar designations to the remaining terms in the above equation, the system can be shown as:

$$Pin + Pgen = Pout + Pdest + Paccum \quad (2)$$

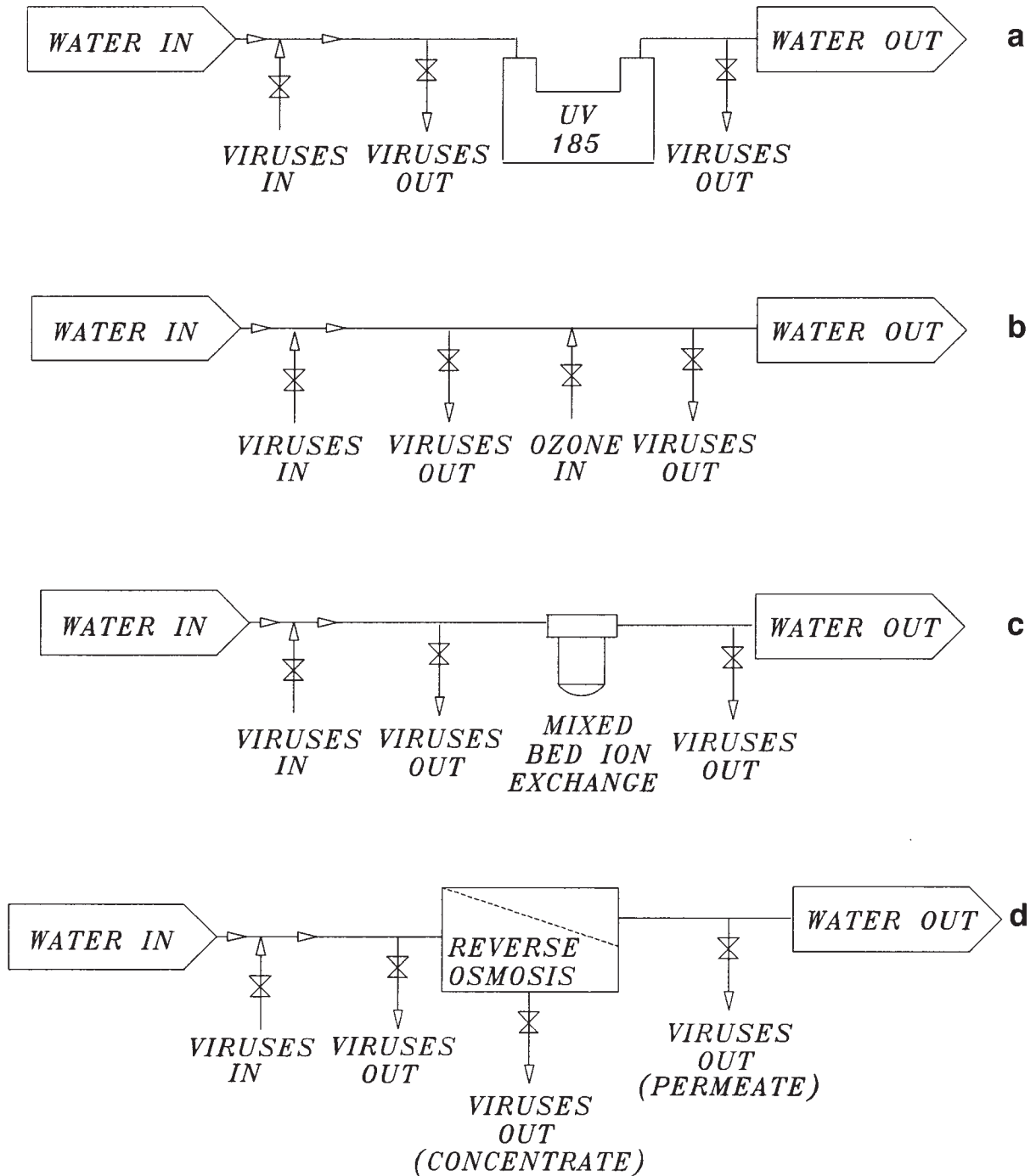

Figure 1 Schematics for virus reactors.

This general viral population balance can be further simplified by assuming that a negligible number of viruses will be generated during the experiment compared to the amount present in the system due to injection. In this case, the generation term 'P_{gen}' vanishes towards zero and the equation simplifies to:

$$P_{in} = P_{out} + P_{dest} + P_{accum} \quad (3)$$

Equation three is the fundamental description of viral behavior within an ultrapure water system and can be

reduced further based on specific knowledge of the individual unit operations.

Simplification of general viral balance for ultraviolet radiation and ozone reactors

The UV and ozone reactors as shown in Figures 1a and b, based on their high turbulence [2] and their relatively low dispersion values [10], are modeled as axial flow reactors with no filtration or particle retention characteristics. As such, the rate of viral accumulation is negligible and the

accumulation term vanishes. Equation three therefore reduces to:

$$P_{in} = P_{out} + P_{dest} \quad (4)$$

Simplification of general viral balance for mixed resin bed reactor

The mixed bed resin reactor consists of a vertical tank filled with positively and negatively charged resin beads in a packed bed (Nuclear Grade Mixed Resin, Ionpure, Bedford, MA, USA). In this unit operation, as shown in Figure 1c, viruses are removed from the water through charge adsorption from the bulk fluid to the resin beads; this form of removal is inert and non-destructive in nature. Since the viruses are not destroyed in the process, the destruction term in Eqn three is vanishingly small. Equation three therefore reduces to:

$$P_{in} = P_{out} + P_{accum} \quad (5)$$

Simplification of general viral balance for reverse osmosis unit

The reverse osmosis system removes viruses through the mechanisms of filtration and path diversion. As shown in Figure 1d, the unit has two exit streams; the first is the product water or *permeate* stream and the second is the waste stream or *concentrate* stream. The permeate stream results from the passing of the feed stream through the reverse osmosis membrane and is expected to be relatively low in viral concentration. To reduce the amount of buildup on the reverse osmosis membrane, the concentrate stream allows a low-pressure exit route for the contaminants. Since the goal of the unit is to produce pure water at high flow rates, the permeate flow is set much greater than the concentrate flow; in this case, the permeate stream flows at 75% of the feed rate, and the concentrate stream flows at 25% of the feed rate.

Since the reverse osmosis membrane typically removes ions from the water (desalination applications), a concentration polarization layer can build up [11]; this charge effect layer has the potential to trap viruses on the membrane surface much in the same way as the viruses are trapped on the ion exchange resin beads, without oxidation. For these reasons, the accumulation term is retained in the equation, the destruction term is minimized and the output terms are split into the permeate and concentrate terms. The viral population balance simplifies to:

$$P_{in} = P_{out_p} + P_{out_c} + P_{accum} \quad (6)$$

where the designations *p* and *c* represent the permeate and concentrate streams, respectively. The only unknown in the equation is the accumulation term.

For the purposes of this initial trial, only the total number of phages observed (typically determined as the total area under the curves shows in Figures 2 and 3) is considered. Future work will include the generation of a theoretical model that solves the differential equations based on the residence time distributions [13], initial injection conditions, temporal variations in bacteriophage concentrations, and loop recycle effects for the entire ultrapure

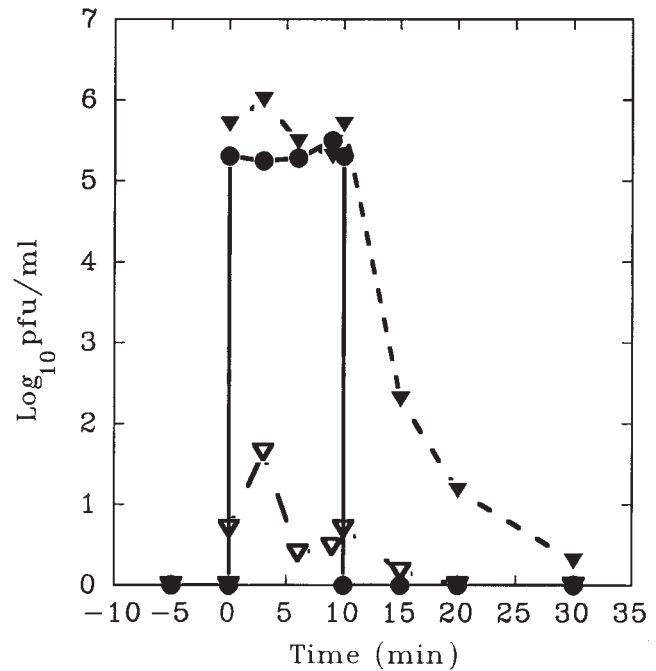

Figure 2 Removal of MS-2 by reverse osmosis, pH = 7.0, T = 21°C. (●—●) Feed water; (▽—▽) permeate; (▼—▼) concentrate.

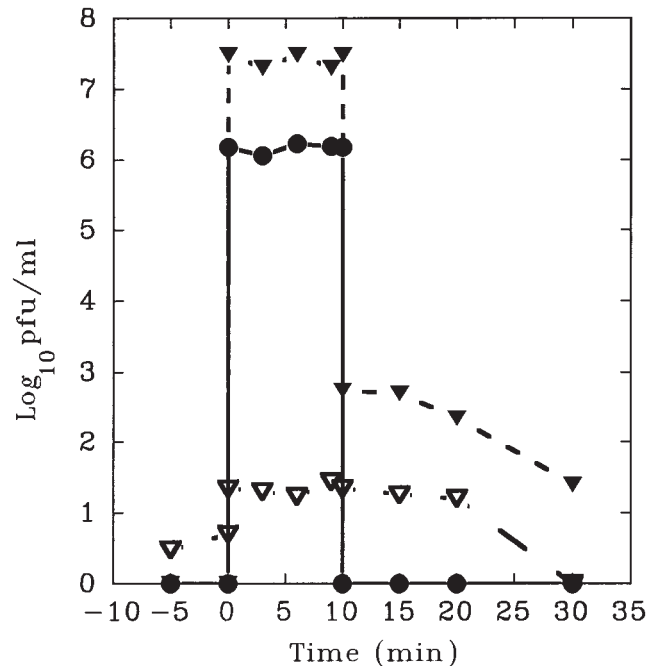

Figure 3 Removal of PRD-1 by reverse osmosis, pH = 7.0, T = 21°C. (●—●) Feed water; (▽—▽) permeate; (▼—▼) concentrate.

water system as determined by the sum of the individual unit operations.

Results

The ultrapure water system is designed to produce water with contaminant levels less than five parts per billion total organic carbon, less than one part per trillion total dissolved

Table 2 Effect of water treatment unit operations on virus concentrations^a

Unit operation ^b	MS2 _{in} ^c	MS2 _{out}	PRD-1 _{in}	PRD-1 _{out}
UV-185 ^d	2.4 ± 1.1 × 10 ⁶	<1	4.0 ± 1.9 × 10 ⁵	<1
Ozone ^e	2.0 ± 1.0 × 10 ⁵	<1	2.6 ± 1.5 × 10 ⁶	<1
Mixed bed ion exchange	1.2 ± 0.5 × 10 ⁶	2.9 ± 1.0 × 10 ⁴	3.1 ± 1.0 × 10 ⁶	8.0 ± 0.4 × 10 ²
Reverse osmosis	2.2 ± 1.3 × 10 ⁵	1.2 ± 0.6 × 10 ¹	1.5 ± 0.9 × 10 ⁶	2.2 ± 1.4 × 10 ¹

^aAll experiments performed in duplicate.

^bAll unit operations display a residence time of 24.4 s.

^cAll viral concentrations are in pfu ml⁻¹.

^dUltraviolet radiation (UV-185 nm) exposure of 40000 μW cm⁻²

^eOzone concentration of 50 μg L⁻¹.

metals, and less than ten viable bacteria as colony forming units per liter of product water [4]. The pH of the water was maintained at 7.0 throughout the ultrapure water system. At no time did injection of bacteriophage into the environment significantly alter the composition of ultrapure water to the point of detection by on-line instrumentation.

Table 2 shows the effect of the single outlet stream oxidizing unit operations on the removal of bacteriophages from the water system including the UV oxidizer and the ozone injection. For MS-2 and PRD-1 injections, the oxidative technologies including UV disinfection and dissolved ozone treatment consistently displayed better than five-log removal of the bacteriophages. The filtration-based reverse osmosis system removed four logs of MS-2 and PRD-1, respectively. The charge-adsorption based mixed bed ion exchange system and the reverse osmosis systems, however, retained approximately 97% of the MS-2 challenge and 99.97% of the PRD-1 challenge.

Using the first order kinetic models shown previously, removal rate constants (*k* values) were significantly greater (*t*-test, confidence level of 90%) using oxidative technologies (UV and ozone) over the adsorption and filtration technologies, as shown in Table 3. UV- and ozone rate constants were found to display greater than three times the mixed bed ion exchange rate constant, and greater than 1.2 times the average rate constant displayed when using reverse osmosis.

The actual sampling profiles from the reverse osmosis experiments are shown for the MS-2 bacteriophage in Figure 2. The filled circles indicate the temporal profile for the injection of the bacteriophage into the reverse osmosis unit. Up until time zero, bacteriophage MS-2 remained undetected in the background (less than 1.0 pfu L⁻¹); to insure the interference due to any potential background level of bacteriophages, a level of 2.16 × 10⁵ pfu ml⁻¹ MS-2 bacteriophage was injected into the system over a period of

10 min. During the same injection period, an average of 12 pfu ml⁻¹ was observed in the permeate or product stream (inverted triangles) while an average value of 5.00 × 10⁵ pfu ml⁻¹ was observed in the concentrate or waste stream (filled triangles). This indicated better than a four-log removal of the 50-nm bacteriophage using this unit operation.

Figure 3 shows the action of the reverse osmosis unit operation on removal of bacteriophage PRD-1. Based on an average injection of 1.48 × 10⁶ pfu ml⁻¹, the product stream showed an average of 22 pfu ml⁻¹, while the concentrate or waste stream showed an average level of 2.40 × 10⁷ pfu ml⁻¹.

Starting with the fundamental equation to describe viral behavior within an ultrapure water system (Eqn 3), we can describe and quantify the effects of the individual unit operations with the application of the unit operation's physical abilities.

For the oxidative technologies (UV and/or ozone), we have shown the only unknown term in Eqn 4 is the viral destruction rate, *Pdest*. Since the UV and ozone reactors have been determined previously from flow characteristics to be ideal plug flow reactors of residence time 'τ' of 24.4 s [4], the phage-containing volume of ultrapure water entering the reactor can be directly measured at the outlet exactly 24.4 s later. By applying a simple delay term to the equation, the rate of viral inactivation is easily determined as the difference in the inlet and outlet rates. For MS-2 and PRD-1, the outlet concentration was so vanishingly small that the initial viral inactivation rate in plaque-forming units per minute (pfu min⁻¹) is calculated as being equal to the injection rate multiplied by the overall system flow rate. For MS-2 and PRD-1, these minimum destruction rates are approximately 2.72 × 10¹⁰ pfu min⁻¹ and 2.98 × 10¹⁰ pfu min⁻¹, respectively.

For the adsorption technology, the mixed bed ion exchange tank, previous work has shown this unit operation to be effectively characterized through the use of a first order continuous stirred tank theoretical model of residence time 'τ' of 24.4 s [4]. From Eqn 5, we can determine the only unknown in the equation, the accumulation term 'Paccum' as the difference between the outlet and inlet terms multiplied by the overall system flow rate. For MS-2 and PRD-1, the accumulation rates using this unit operation are 1.29 × 10¹⁰ pfu min⁻¹ and 3.51 × 10¹⁰ pfu min⁻¹, respectively.

The filtration technology, the reverse osmosis system, is

Table 3 Observed rate constants for virus removal

Virus	UV-185 ^a	Ozone ^a	Mixed bed ion exchange ^b	Reverse osmosis ^c
MS-2	15.5 ± 0.5	12.9 ± 0.6	3.9 ± 0.1	10.4 ± 0.1
PRD-1	13.9 ± 0.4	15.4 ± 0.8	8.2 ± 0.8	11.9 ± 0.1

^aFirst order reaction rate constant min⁻¹.

^bFirst order adsorption rate constant min⁻¹.

^cFirst order filtration rate constant min⁻¹.

somewhat more complicated than the other systems. As shown in Eqn 6, four terms consisting of three streams and an accumulation must be addressed to adequately characterize this unit operation. Since the inlet 'Pin', the permeate 'Pout_p' and concentrate stream 'Pout_c' can be physically monitored, the only unknown in the equation is the accumulation term 'Paccum'. Multiplying the inlet and outlet bacteriophage concentrations by their respective flow rates, then subtracting the bacteriophage levels in the outlet streams from the level in the inlet stream, generates the accumulation term in plaque-forming units per minute (pfu min⁻¹) over the 10-min injection level. For MS-2 and PRD-1 bacteriophages, the accumulation rate was determined to be 3.56 × 10⁷ pfu min⁻¹ and 2.80 × 10⁶ pfu min⁻¹ respectively.

Discussion

Although previous work has shown the effect of the ultrapure water environment on bacteriophage inactivation [6], the amount of information currently available on viral inactivation by standardized ultrapure water generating unit operations operating in ultrapure water environments is minimal.

The effect of traditional environmental factors of potable water including temperature, pH, total dissolved solids (TDS), and chlorine concentration on virus inactivation can be considered to be negligible in the polishing loop of the ultrapure water system, as these factors are generally held to within tightly controlled limits (temperature and pH), while contaminant levels are near zero (TDS and free chlorine concentration) [6]. Discussion is therefore focused on the abilities of the solvent-like nature of ultrapure water [6] and the effect of ultrapure water unit operations on the disruption of cellular structure and resulting loss of infectivity. A list of factors that can influence viral infectivity in an ultrapure water system may therefore include: exposure time to ultrapure water (solvation, turbulence, shear), ultraviolet radiation dose, ozone dose, physical filter characteristics (including pore size and surface charge potential), ion exchange bed adsorption efficiency, and exposure to low pressure environments (vacuum degasification). This list has been generated based on experience, and is by no means inclusive.

In the case of the ultrapure water system, should the unit operations fail to remove the bacteriophages and their breakdown products (tail fibers, genetic materials, etc) from the environment, the solvent (ultrapure water) can transport these contaminants to the point of use and potentially generate an electrical defect on the microelectronics device.

Since the types and concentrations of viruses in the ultrapure water systems have not been studied in detail, it is difficult to quantify the interactions between these unit operations in removing these bacteriophages in this unique environment, and even more difficult to determine the numbers of phages and breakdown products that would contaminate the point of use. Characterization and quantification of bacteriophages in the ultrapure water systems used in industry is the focus of future work.

MS-2, an RNA-containing *E. coli* phage, and PRD-1, a DNA-containing *S. typhimurium* phage, were selected to

represent examples of RNA and DNA viruses that could exist in an ultrapure water system, and show their fates when exposed to typical unit operations in the ultrapure water environment.

Based on the theoretical first order rate constants observed, the oxidation technologies including UV and ozone consistently displayed greater effectiveness in inactivating the selected bacteriophages when compared to the typically non-destructive adsorption and filtration technologies of mixed bed ion exchange and reverse osmosis, respectively. At no time were any of the test bacteriophages consistently detected at the outlet of the reactors (sensitivity to 1.0 pfu ml⁻¹). From the standpoint of keeping the point of use as free from contamination as possible, this suggests that some form of oxidative technology, such as the trace injection of dissolved ozone, then destruction by a UV unit before reaching the point of use, may aid in removal of contaminants such as viruses and bacteria. It is standard practice to use filtration technologies such as reverse osmosis and ultrafiltration as the last line of defense for the point of use [3]. Should a significant number of bacteria and/or viruses enter this last unit operation, the data indicate such contaminants have the potential to survive treatment and exit from the unit operation to potentially contaminate the microelectronic, pharmaceutical, or power generation point of use.

Since the study of viruses in ultrapure water systems is a relatively new field, the types and concentrations of viruses can vary from one system to another. The generation of a site-independent theoretical model can aid in the prediction of viral numbers at any point in an ultrapure water system. As mentioned above, the oxidative unit operations including UV and ozone can be modelled with a first order plug flow model, where the only unknown in the equation is the intrinsic rate constant.

Since the adsorptive and filtration unit operations, including mixed bed ion exchange and reverse osmosis, may be modelled with combinations of continuous stirred tank reactors as well as ideal plug flow reactors, the outlet or product flow streams are far more complicated in terms of predicting the outlet virus levels. It can be seen from Figures 2 and 3 that the outlet profiles for the reverse osmosis system are shaped differently than the basic step-function displayed by the inlet function. This washing out of the unit operation can result in the detection of bacteriophages in the outlet stream of the unit operation long after the injection of viruses into the unit operation has been terminated.

Future work will determine the amount of dispersion in the reactor and will further characterize the flow patterns in the unit operation; this will aid in the accurate prediction of bacteriophage numbers out of the non-ideal reactors.

Conclusions

- (1) All tests showed that the oxidative technologies such as UV irradiation and injections of dissolved ozone were not only significantly more effective in removing bacteriophages from the ultrapure water environment, but were also capable of removing far greater numbers than originally estimated.

- (2) Since bacteriophages were detected at the outlets of the ion exchange and reverse osmosis unit operations, significant numbers of phages may contaminate the point of use when a large number of phages enter these unit operations and when these unit operations are used as the last line of defense.

The first generation of the viral population balance with the corresponding fundamental postulates has been presented. Future work will further refine this model towards the ultimate goal of quantifying viruses in ultrapure water systems.

Acknowledgements

The authors wish to acknowledge The University of Arizona, Tucson, Arizona, and Sematech, Austin, Texas for providing ultrapure water for testing and evaluation.

References

- 1 American Public Health Association. 1992. Standard Methods for the Examination of Water and Wastewater, Washington, DC.
- 2 Bennet CO and JE Myers. 1982. Introduction to fluid behavior. In: Momentum, Heat and Mass Transfer, 3rd edn (Carberry JJ, JR Fair, MS Peters and WR Schowalter, eds), pp 19–21, 143–145, McGraw-Hill Book Company, NY.
- 3 Burggraaf P. 1987. Ultrapure water focus. *Semiconductor Int* 5: 128–137.
- 4 Governal RA. 1992. Overview of the concept of ultrapure water. In: *Characterization and Removal of Organic Contaminants from Ultrapure Water Systems*, pp 39–45, University Press, NY.
- 5 Governal RA, AL Bonner and F Shadman. 1991. Oxidation and removal of organic particles in DI water polishing loops using combined ozone and UV treatment. In: *Proceedings of Watertech '91 Conference and Exposition*, pp 74–88, San Jose, CA.
- 6 Governal RA and CP Gerba. 1997. Persistence of MS-2 and PRD-1 bacteriophages in an ultrapure water system. *J Ind Microbiol Biotechnol* 18: 297–301.
- 7 Governal RA, CP Gerba, M Yahya and F Shadman. 1992. Comparison of assimilable organic carbon (AOC) and total oxidizable carbon (TOC) in ultrapure water systems. *J Appl Environ Microbiol* 58: 724–726.
- 8 Henley M. 1995. Market review: semiconductor industry expansion should continue. *Ultrapure Water* 13: 15–20.
- 9 Hoerl A, M Nashed, J McKetta and I Silverberg. 1984. Mathematics. In: *Perry's Chemical Engineering Handbook*, 6th edn (Perry RH, DW Green and JO Maloney, eds), pp 85–87, McGraw-Hill Book Company, NY.
- 10 Levenspiel O. 1972. Design for single reactors. In: *Chemical Reactor Engineering* (M Dudukovic, ed), pp 124–132, John Wiley and Sons, NY.
- 11 Meltzer TH. 1993. Reverse osmosis, ultrafiltration, and electrically driven demineralizations. In: *High-Purity Water Preparation for the Semiconductor, Pharmaceutical, and Power Industries* (J Staton, ed), pp 437–441, Tall Oaks Publishing, Littleton, CO.
- 12 Randolph AD and MA Larson. 1988. The population balance. In: *Theory of Particulate Processes: Analysis and Techniques of Continuous Crystallization*, 2nd edn, pp 50–79, Academic Press, San Diego, CA.
- 13 Smith JM. 1981. Deviation from ideal reactor performance. In: *Chemical Engineering Kinetics*, 3rd edn (JV Brown, ed), pp 268–294, McGraw-Hill Book Company, NY.